

6100 Broadcast Audio Delay



User's Guide

Revision A02, 17 July 2002

Symetrix part number: 5361000A02

Subject to change without notice.

Copyright 2002, Symetrix, Inc. All rights reserved.

AirTools™ is a registered trademark of Symetrix, Inc.

All other trademarks referenced in this User's Guide are the property of their respective holders.

Mention of third-party products is for informational purposes only and constitutes neither an endorsement nor a recommendation. Symetrix assumes no responsibility with regard to the performance or use of these products.

Under copyright laws, the content of this User's Guide remains the property of Symetrix, Inc.

Contents

1 Introduction	1
2 Safety Information	2
Operator safety summary	2
Other safety information	3
3 Summary Product Description	4
Front panel view	4
Rear panel view	5
4 Installation	6
AC line connection	6
Mounting in an equipment rack	6
Analog audio input connections	6
Analog audio output connections	7
Signal level	7
Digital audio connections	7
Word clock connection	7
Typical system block diagram	7
Remote control & indicators connector	8
Automation connector	8
RS-232 and RS-485 connections	8
TC89 time code connections	8
Menu tree	8
5 Operation	10
Operational status	10
INPUT/OUTPUT LEVEL (dB) display	10
The START button	10
The EXIT button	10
The COUGH button	11
The DUMP button	11
The A1 through A4 relay status LEDs	11
The DELAY time (seconds) display	11
6 Troubleshooting	12
Solutions to common problems	12
Less common problems	12
7 Warranty and Service	13
The AirTools™ Limited Warranty	13
Limitation of Liability	13
Servicing the 6100	14
Return authorization	14
In-warranty repairs	14
Out-of-warranty repairs	14

Appendices

A Specifications	15
Architects and engineers specifications	15
Technical specifications	15
B Remote Indicator & Control Interface wiring	16
Remote panel switch pinouts	16
Remote panel LED indicator pinouts	16
Typical remote panel switch wiring	17
Typical remote panel LED wiring	17
C Automation wiring	18
Automation connector pinout	18
D RS-232/RS-485 Control Protocol	19
Introduction	19
Getting Started	19
Returned codes	20
Checksum	20
Commands	20
Write commands	20
Read commands	21
E Block Diagram	23

1

Introduction

Thank you for your purchase of the AirTools™ model 6100 Broadcast Audio Delay, engineered by Symetrix. The 6100 has been designed to give broadcasters unequaled performance combined with ease of use and reliability. This manual will guide you through the installation and operation of the 6100, and provide valuable tips on how to interface with other equipment in your studio or control room.

The 6100 gives the host or producer of a talk show the power to prevent the broadcast of unwanted profanities or comments from guests, hosts or telephone callers. As the program begins, the 6100 gradually and unobtrusively delays or "stretches out" the program until up to 20 seconds of 20kHz bandwidth stereo audio is stored in memory. When a person says something the host or producer does not think appropriate for the broadcast, he or she presses the DUMP button and a user preset length of memory is cleared, thereby preventing the unwanted audio from reaching the airwaves. Meanwhile, the host releases the offending caller from the telephone line and proceeds with the program. After the DUMP button has been pressed, the 6100 automatically begins to stretch (time expand) the program audio again until the user preset length of delay is attained.

Several minutes in advance of the end of the talk show, the host or producer presses the EXIT DELAY button and the 6100 begins to time compress the program audio until there is nothing left in the 6100's memory (zero seconds delay). At this point the program is back in "real time."

A unique feature of the 6100 is the COUGH button, which allows the host to make impromptu interruptions in the program for up to 20 seconds while keeping the audience unaware of the break. When the COUGH button is pushed, the 6100 plays from memory while the button is held in. As soon as the button is released, the 6100 automatically begins to refill the memory. The host can cough, have a quick drink of water, or make a comment to the producer or engineer without any perceptible program interruption.

The 6100 uses the latest in delta-sigma conversion technology coupled with advanced digital signal processing (DSP) algorithms. This combination produces a product that meets or exceeds the highest broadcast standards in terms of low noise, low distortion, and superb signal processing.

The 6100's logical, easy to use control panel holds no hidden surprises. The product is easy to learn and simple to use. In the sections that follow you'll find information on installation, operation, and specific applications of the 6100. We follow this with a troubleshooting guide, warranty and service information, and detailed specifications.

As with all Symetrix engineered products, the 6100 has been designed and built to the highest standards of the broadcast industry. Our company is committed to excellence in product design, manufacturing, and service. Please do not hesitate to contact us with your questions or comments.

2 Safety Information

Operator safety summary

The information in this summary is intended for persons who operate the equipment as well as repair personnel. Specific warnings and cautions are found throughout this manual wherever they may apply; they do not appear in this summary.

The notational conventions used in this manual and on the equipment itself are described in the following paragraphs.

Equipment markings

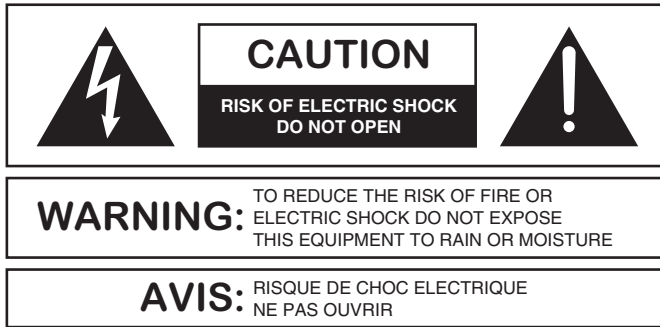

SEE OWNERS MANUAL. VOIR CAHIER D'INSTRUCTIONS.
No user serviceable parts inside. Refer servicing to qualified service personnel.
Il ne se trouve a l'interieur aucune piece pouvant entre reparée l'usager.
S'adresser a un reparateur competent.

The lightning flash with arrowhead symbol within an equilateral triangle is intended to alert the user of the presence of uninsulated "dangerous voltage" within the product's enclosure that may be of sufficient magnitude to constitute a risk of electric shock to persons.

The exclamation point within an equilateral triangle is intended to alert the user of the presence of important operating and maintenance (servicing) instructions in the literature accompanying the 6100 (i.e. this manual).

Caution

To prevent electric shock, do not use the polarized plug supplied with the 6100 with any extension cord, receptacle, or other outlet unless the blades can be fully inserted to prevent blade exposure.

Terms

Several notational conventions are used in this manual. Some paragraphs may use Note, Caution, or Warning as a heading. These headings have the following meaning:

- Note** Identifies information that needs extra emphasis. A Note generally supplies extra information to help you to better use the 6100.
- Caution** Identifies information that, if not heeded, may cause damage to the 6100 or other equipment in your system.
- Warning** Identifies information that, if ignored, may be hazardous to your health or that of others.

In addition, certain typefaces and capitalization are used to identify certain words. These are:

- CAPITALS** Controls, switches or other markings on the 6100's chassis.
- Boldface** Strong emphasis.

Other safety information

Power source

This product is intended to operate from a power source that does not apply more than 250 volts RMS between the power supply conductors or between either power supply conductor and ground. A protective ground connection, by way of the grounding conductor in the power cord, is essential for safe operation.

Grounding



The chassis of this product is grounded through the grounding conductor of the power cord. To avoid electric shock, plug the power cord into a properly wired receptacle before making any connections to the product. A protective ground connection, by way of the grounding conductor in the power cord, is essential for safe operation.

Danger from loss of ground

If the protective ground connection is lost, all accessible conductive parts, including knobs and controls that may appear to be insulated, can render an electric shock.

Proper power cord

Use only the power cord and connector specified for the product. Use only a cord that is in good condition.

Proper fuse

The fuse is mounted internally and is not considered user serviceable. For reference only, the fuse is a 2 Amp 250 VAC normal blow fuse 5x20mm in size.

Operating location

Do not operate this equipment under any of the following conditions: explosive atmospheres, in wet locations, in inclement weather, improper or unknown AC mains voltage, or if improperly fused.

Stay out of the box

To avoid personal injury or injury to others, do not remove the product covers or panels. Do not operate the product without the covers and panels properly installed.

3 Summary Product Description

This chapter provides a basic overview of the 6100 by describing the input and output connections, power connection, operating controls, front panel LED indicators, and the remote indicator and control interface. Use this information to acquaint yourself with the product. **Chapter 4 (Installation)** gives details on installing the 6100 in your system and **Chapter 5 (Operation)** gets into specific applications and uses of the 6100 in detail.

Front panel view

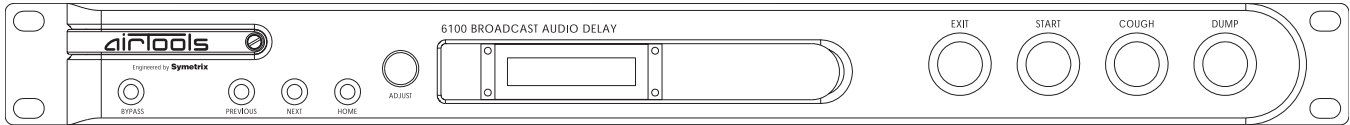

- The BYPASS button places the 6100 in either BYPASS or OPERATE modes. In BYPASS mode the incoming signals are directly routed (via relays) to the 6100's outputs, thereby bypassing any internal circuitry. In addition, the digital I/O is relay bypassed. In BYPASS mode, the front panel and remote controls have no effect on the operation of the 6100. In OPERATE mode, the incoming signals are processed through the 6100's analog and digital circuitry, and all front panel and remote controls are fully functional.
- The PREVIOUS button displays the previous menu of the 6100's menu setup hierarchy in the LCD display.
- The NEXT button displays the next menu of the 6100's menu setup hierarchy in the LCD display.
- The HOME button returns the 6100's LCD DISPLAY to the default operating screen which shows the following information:
 1. The top line of the LCD DISPLAY shows the input or output levels for audio channels 1 and 2. Each is labeled with a numeral 1 or 2 respectively to the left. A bar graph meter will display to the right of each numeral. Each bar graph increment represents 1dB of signal for a peak level metering range of -40 to 0dBfs.
 2. The bottom line of the LCD DISPLAY shows the current operating status of the 6100. For example, 6100 BYPASSED, DELAY REMOVED, ADDING DELAY TIME, REDUCING DELAY TIME, WAITING FOR RELEASE, MUTED, or MAXIMUM DELAY.
- The ADJUST knob scrolls through the available parameters to each setup menu item.
- The LCD DISPLAY shows the current menu item in the setup menu hierarchy as well as its current setting. It also shows the 'home' screen as described under HOME (see above).
- The A1 through A4 LEDs show the state of the four internal relays used for delay automation. The LEDs will be off when the relays are unenergized, green when energized and red when cued to be energized. Further description of this feature is provided in **chapter 5**.
- The DELAY numerical readout shows the length of delay time built up by the 6100 in tenth of a second increments.
- The EXIT DELAY button initiates the gradual reduction of delay time. Once this button is pressed, assuming no other control button is subsequently pressed, the 6100 will proceed to incrementally reduce delay time until a zero delay is achieved.
- The START DELAY button initiates the gradual increase of delay time. Once this button is pressed, assuming no other control button is subsequently pressed, the 6100 will proceed to incrementally increase delay time until a user-determined preset second delay is achieved up to a possible full 20 seconds.
- Pressing the COUGH button pauses the incoming signal while allowing the output signal to play (uninterrupted) from the 6100's memory. The 6100 will continue to play from memory for so long as the button is pressed. When the COUGH button is released, the 6100 resumes recording into memory and "splices out" the silence created while the button was pressed. The 6100 then begins to rebuild the delay time used while the COUGH button was pressed. The listener will be aware of a program interruption if and only if the button is held for a time exceeding the time in memory, in which case the input is muted.
- Pressing the DUMP button erases a user-determined portion of the 6100's delay memory. The 6100 will then proceed to splice back together everything except the erased audio. Next, if no other control button is subsequently pressed, the 6100 will proceed to incrementally increase delay time until the user-determined second delay is again achieved. See **chapter 5** for further explanation of the DUMP function and its delay length settings.

Rear panel view

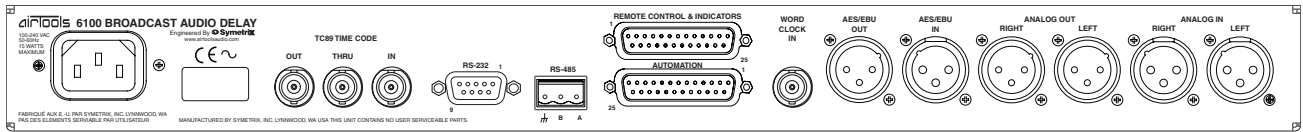

- The AC INPUT connector accepts nominal AC power sources of 100 - 240 volts [see **Appendix A (Specifications)** for voltage tolerance ranges]. See **chapter 4 (Installation)** for details on the detachable (IEC) power cable.
- The TC89 TIME CODE connections allow the display of TC89 Time Code with the applied delay when the OUT connector is connected to an external Time Code reader and a valid TC89 source is connected to the IN connector. Additionally, a dual window Time Code reader could be used in conjunction with the THRU and OUT connectors in order to see both the current and delayed Time Code positions simultaneously.
- The RS-232 and RS-485 connectors provide a way to control the 6100 via these interfaces. See **Appendix D** for the control protocol.
- The REMOTE CONTROL AND INDICATOR interface provides a way to connect to the Symetrix RC-610 or a user supplied remote control and/or indicator panel. See **Appendix B** for details.
- The AUTOMATION interface provides a way to interface with the four internal relays used for delay automation. See **Appendix C** for pinout.
- The WORD CLOCK IN connection allows the 6100 to digitally sync to a house sync source or any word clock providing device.
- The AES/EBU IN connector provides stereo digital input in the AES/EBU format. The 6100 can also sync to the AES/EBU clock present in the AES/EBU digital stream.
- The AES/EBU OUT connector provides stereo digital output in the AES/EBU format.
- The ANALOG OUTPUT LEFT and RIGHT audio connectors are electronically balanced, line level, low impedance outputs. Pin 1 is ground. Pin 2 is high. Pin 3 is low.
- The ANALOG INPUT LEFT and RIGHT audio connectors are electronically balanced, line level, bridging inputs. Pin 1 is ground. Pin 2 is high. Pin 3 is low.

4 Installation

AC line connection

A sticker on the rear of the unit indicates the nominal voltage setting for the unit as it left the Symetrix factory. If this does not correspond to the voltage setting for your locale then do not attempt to apply power to the 6100. Instead, return the unit to your local Symetrix distributor for modification.

The 6100 is shipped from the Symetrix factory with a detachable AC power cable (IEC standard) included. Depending on the intended destination, the power plug is either the US type (intended for 117 VAC use), or the Europlug type. If the power cable's plug is not right for your locale, then please contact your local Symetrix distributor for the proper cable.

Once you have determined that the 6100's operating voltage matches that of your locale and you are ready to begin, follow these steps:

- 1 Plug the socket end of the power cable into the recessed AC power receptacle on the back of the 6100.
- 2 Plug the other end of the power cable into a three-hole grounded outlet or power strip.



WARNING The 6100 is intended to be electrically grounded. It has been provided with a three-wire grounding plug - a plug that has a third (grounding) pin. This plug will fit only a grounded AC outlet. This is a safety feature. If you are unable to insert the plug into the outlet, contact a licensed electrician to replace the outlet with a properly grounded outlet. Do not defeat the purpose of the grounding plug!

Mounting in an equipment rack

The 6100 occupies one rack space (1U) in a standard equipment rack with a width of 19" (48.3 cm), a depth of 7.8" (19.8 cm), and a height of 1.75" (4.45 cm). Allow at least 4" (10.16 cm) behind the unit for the protrusion of connectors. We recommend you take care not to mount the 6100 next to devices that emit large electromagnetic fields, such as audio power amplifiers. To do so may compromise the noise performance of the 6100. The 6100 has been designed to conform to mechanical guidelines as described in EIA Standard RS-310-C and IEC Recommendation 297.

Analog audio input connections

The 6100's audio input connections are via standard female XLR jacks located on the rear panel. For optimum system performance we recommend that the 6100 be connected to balanced signal sources. If this is not practical in your situation, then you may connect to unbalanced sources. The following diagram illustrates recommended cable wiring practices.

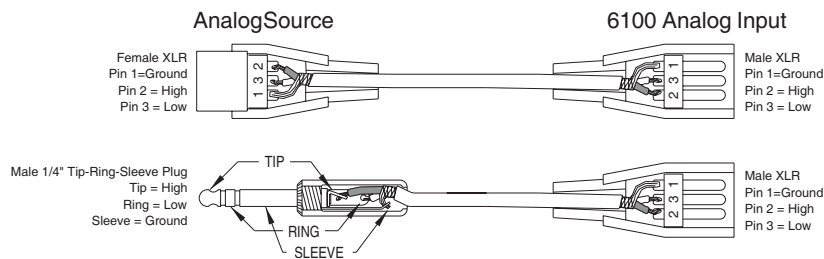

Analog audio output connections

The 6100's audio output connections are via standard female XLR jacks located on the rear panel. For optimum system performance we recommend that the 6100 be connected to balanced devices. If this is not practical in your situation, then you may connect to unbalanced devices. The following diagram illustrates recommended cable wiring practices.

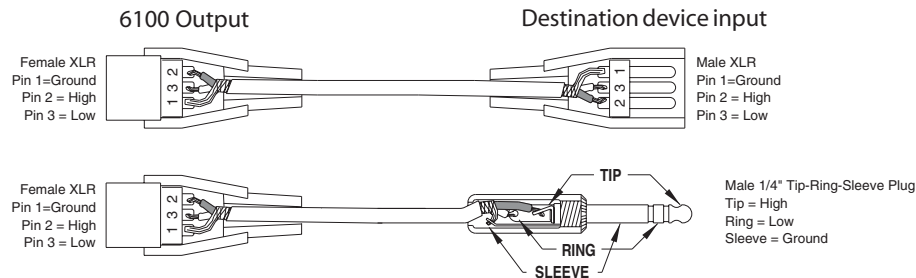

Signal Levels

The 6100 has been designed to operate at standard nominal broadcast signal levels of either 0VU = +4dBu or 0VU = +8dBu. To provide even more flexibility, the 6100 can also operate at -10dBu and 0dBu. The 6100's operating level can be adjusted by navigating to the NOMINAL INPUT and/or OUTPUT LEVEL pages in the setup menu on the LCD display. A full discussion of the setup menu can be found on **page 8**.

Digital audio connections

The 6100 has connections for stereo digital audio input and output in the form of AES/EBU. It is recommended that you obtain the highest quality AES/EBU-specific cable from a reputable vendor. Even though the analog input and output connectors look to be the same XLR type connectors as the AES/EBU connectors, they are very different and require different types of cable. More information on how to configure the 6100 for digital I/O can be found on **page 8**.

Word clock connection

If using the 6100 in a digital audio environment, it may be necessary for the 6100 to slave its internal clock to an external master clock or house sync source. This can be accomplished by connecting a word clock feed to the WORD CLOCK IN connector on the back of the 6100 using a BNC terminated 75-ohm word clock cable. The 6100 must then be set to use this word clock connection by navigating to the DIGITAL INPUT SYNC page in the 6100's setup menus. See **page 8**.

Typical system block diagram

In most broadcast applications it is recommended that the 6100 be connected between the station's on air console and the station's audio processing equipment. In other words, the console's main stereo (or mono) output bus should connect to the 6100's inputs, and the 6100's outputs should feed the "down stream" signal processing. As discussed in **Chapter 5 (Operation)**, the 6100 will automatically remove itself from the signal path when not in use.

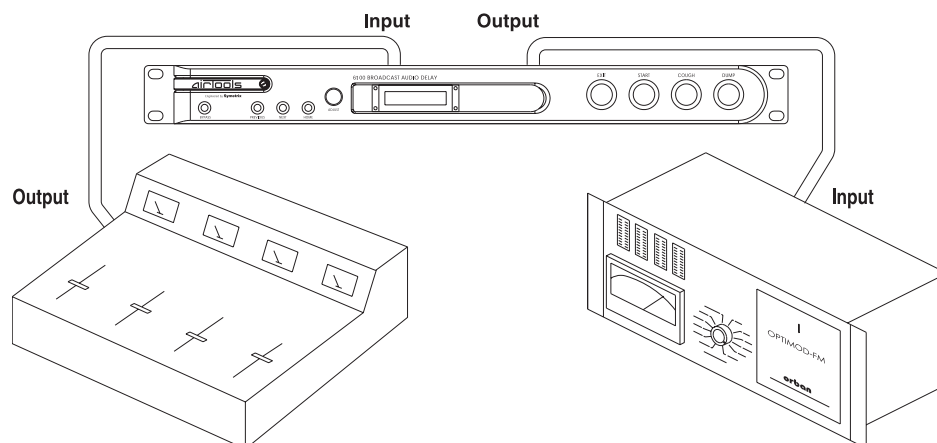

Remote control & indicators connector

This DB-25 connector allows you to remotely control the EXIT DELAY, START DELAY, COUGH and DUMP functions of the 6100. You can also remotely view the status items DELAY INACTIVE, DELAY ACTIVE, 3.5 SECONDS delay accumulated and 7.5 SECONDS delay accumulated. This connector interfaces directly with the Symetrix RC-610 Remote Control. Alternatively, you can use the pinout provided in **Appendix B** to wire your own remote and indicators.

Automation connector

This DB-25 connector provides a way to interface with the four internal relays used for delay automation. The 6100 has four internal relays that may be independently used to control station automation events. The relay closures (outputs) are triggered by input closures that can be either manual (a momentary switch closure) or electrical (TTL logic low). When an input closure takes place the audio entering the delay at that moment is 'tagged'. When the tagged audio reaches the output of the delay it's corresponding relay closes for a time equal to the length of the input closure.

A typical purpose for automation would be with the use of sync pulses provided by a nationally syndicated broadcast that is being relayed by a local station. The sync pulses can be used to automate the start and exit for the 6100's delay. Another use would allow for a DJ to automate the exit of the delay to coincide with a commercial break allowing the DJ to go on break without having to wait for the delay exit in real time. See **Appendix C** for pinout.

RS-232 and RS-485 connections

Using standard RS-232 (DB-9 connector) and RS-485 (Euroblock connector) connections, one can control certain functions of the 6100 remotely with custom serial controller interfaces. See **Appendix D** for the control protocol.

TC89 time code connections

The 6100 provides IN, THRU and OUT connections on BNC connectors for TC89 time code. One can use these ports in conjunction with a dual window time code reader/display in order to view real time against delay time. Simply connect a TC89 source into the IN port and then connect the THRU port to the reader/display to be used for real time and connect the OUT port to the reader/display to be used for delay time.

Menu tree

HOME - displays the input/output levels for audio channels 1 and 2 on the top line in a bar graph fashion and displays the current operating status of the 6100 (BYPASSED, DELAY REMOVED, ADDING DELAY TIME, REDUCING DELAY TIME, WAITING FOR RELEASE, MUTED, or MAXIMUM DELAY) on the bottom line. You can get to this default display at any time by pressing the HOME button.

The following table illustrates the 6100's menu tree with the menus and their options listed in the order that they would appear if you were to advance through the menu tree using the NEXT button.

MENU	OPTION
SIGNAL INPUT SOURCE	ANALOG AES/EBU
NOMINAL INPUT LEVEL	-10 dBu +0 dBu +4 dBu +8 dBu
NOMINAL OUTPUT LEVEL	-10 dBu +0 dBu +4 dBu +8 dBu
DIGITAL INPUT SYNC	INTERNAL 48KHZ WORD CLOCK AES/EBU
DELAY TIME	0.0 to 20.0 SECONDS (in 0.1 second increments)

MENU	OPTION		
DUMP LENGTH	THIRD HALF WHOLE		
ALGORITHM	GAP DETECT	Waits for gaps or pauses in speech and then splices audio. Minimal delay artifacts.	Very fast delay build or exit times with speech only program when known maximum build and exit times are not required.
	GAP DETECT & CATCH UP	If gaps do not naturally occur then splicing is forced. Some audible splice artifacts.	Use for building and exiting delay with music + speech when known maximum build and exit times are required.
	CONTINUOUS	Continuously forces splicing regardless of program content. Some audible splice artifacts.	Use for building and exiting delay with music only when known maximum build and exit times are required.
	PITCH SHIFT	Uses gradual, subtle pitch shifting instead of splicing to increase or decrease delay.	Use with music or music + speech when minimal artifacts are required. Build and exit times are predictable.
DELAY RATIO	10:1 to 40:1		
BARGRAPH MODE	PRE DELAY POST DELAY		
AUTOMATION TRIM	EARLY: 200 mS		
	EARLY: 180 mS		
	EARLY: 160 mS		
	EARLY: 140 mS		
	EARLY: 120 mS		
	EARLY: 100 mS		
	EARLY: 80 mS		
	EARLY: 60 mS		
	EARLY: 40 mS		
	EARLY: 20 mS		
	CURRENT DELAY		
	LATE: 20 mS		
	LATE: 40 mS		
	LATE: 60 mS		
	LATE: 80 mS		
	LATE: 100 mS		
	LATE: 120 mS		
	LATE: 140 mS		
	LATE: 160 mS		
LATE: 180 mS			
LATE: 200 mS			
REAR SERIAL PORT	RS-232 (DB-9) RS-485 (3-PIN EURO)		
SERIAL PORT BAUD	9600 19200 38400		
UNIT NUMBER	ID: (1 through 255)		

5 Operation

This section describes in more detail the 6100's front panel controls and indicators.

Operational status

The BYPASS button places the 6100 in either BYPASS or OPERATE modes. In BYPASS mode the incoming analog signals are directly routed (via relays) to the 6100's outputs, thereby bypassing any internal circuitry. Additionally, the digital input is directly routed to the digital output bypassing the digital receiver. In BYPASS mode the front panel and remote controls have no effect on the operation of the 6100. In OPERATE mode, when the delay is active, the incoming signals are processed through the 6100's analog and digital circuitry, and all front panel and remote controls are fully functional.

It is recommended that the 6100 remain in the OPERATE mode at all times. Typically, the 6100 would be placed in the BYPASS mode only if the unit were to malfunction. By design, a loss of mains (AC) power to the 6100 will force the 6100's audio bypass relays to route the incoming signal directly to the 6100's output.

BYPASS status is shown in two places on the 6100. The first is the second line of the home screen on the LCD display. When in BYPASS mode, the status display line will read "6100 BYPASSED." The second place is the 7 segment delay display to the right of the LCD display. When in BYPASS mode, this display will read "BYP".

When the 6100 is in OPERATE mode, the second line of the home screen on the LCD display will show the current operational status. It will read "DELAY REMOVED, ADDING DELAY TIME, REDUCING DELAY TIME, WAITING FOR RELEASE, MUTED, or MAXIMUM DELAY." The 7 segment delay display will show the current delay as numerical value.

INPUT/OUTPUT LEVEL (dB) display

The INPUT/OUTPUT LEVEL (dB) provides a visual reference of the input (PRE DELAY) or output (POST DELAY) signal. There are separate bar graph displays for each of the two channels and appears on the first line of the home screen in the LCD display. As previously stated, the meters have a range of -40 to 0dBfs. You can use these meters as a guide to help set the input and output operating level of the 6100. Whatever your input levels are, fine adjustment of the input signal must be done ahead of the 6100 (typically with the master bus fader of the broadcast console).

The START button

The START button initiates the gradual increase of delay time. When a radio talk show is to begin, the first action for the operator of the 6100 is to press the green START button. Once this button has been pressed, its light will blink for as long as delay time is increasing. The 7 segment DELAY display on the right end of the LCD screen displays the amount of time in memory at any given instant. From a starting point of zero delay time, the amount of time that it takes to achieve the maximum preset delay depends upon the program material and the maximum delay length set by the user. Once the START button is pressed, assuming no other control button is subsequently pressed, the 6100 will proceed to incrementally increase delay time until the maximum preset delay is achieved.

The EXIT button

The EXIT button initiates the gradual decrease of delay time. Several minutes in advance of the end of a radio talk show, the operator of the 6100 must press the yellow EXIT button. Once this button is pressed, its light will blink as long as delay time is decreasing. The 7 segment DELAY display on the right end of the LCD screen displays the amount of time in memory at any given instant. The amount of time that it takes to reduce the delay time to zero seconds depends upon the program material and the maximum delay length set by the user. Once the EXIT button is pressed, assuming no other control button is subsequently pressed, the 6100 will proceed to incrementally decrease delay time until a zero delay time has been reached. Once zero delay has been reached, "DELAY REMOVED" will be displayed as a status on the second line of the home screen in the LCD display.

The COUGH button

The COUGH button allows the host to make impromptu interruptions in the program for up to the maximum amount of time in memory while keeping the audience unaware of the break. When the COUGH button is pushed and held in, the 6100 plays from memory and mutes incoming audio. As soon as the button is released, the 6100 resumes recording into memory and "splices out" the silence created while the audio was muted. The 6100 then begins to rebuild the delay time used while the COUGH button was pushed. The host can cough, have a quick drink of water, or make a comment to the producer or engineer without any perceptible program interruption. If the COUGH button is pressed for an amount of time exceeding the amount of time in memory, the result will be muted output audio (dead air).

The DUMP button

The DUMP button should be pressed as soon as an unwanted comment is heard. Once pressed, a length of audio, as set by the user, in memory is instantly erased. The 6100 will then automatically "splice" around the erased audio so the audience hears no dead air. Please understand that if the talk show host has not given the 6100 time to build up to enough seconds of delay to cover the audio to be dumped then when he momentarily hits the DUMP button an obscenity may get on the air. The user has the choice of setting the 6100 to DUMP a THIRD, HALF or the WHOLE memory.

The 6100 also allows the host extra protection in the form of muting if he purposely holds down the DUMP button. Holding down the button long enough would erase the entire memory and mute the output of the 6100 until the DUMP button is released. This provides a "panic button" function for use if all hell breaks loose. The muting function does not activate when the DUMP button is pushed and quickly released.

After a DUMP command the 6100 automatically reenters the last mode it was in either building or releasing memory as appropriate.

The A1 through A4 relay status LEDs

The A1 through A4 LEDs show the state of the four internal relays used for delay automation. The LEDs will be off when the relays are unenergized, green when energized and red when cued to be energized. The pinout for the DB-25 connector on the rear of the 6100 is in **Appendix C**. One can use this pinout to build a custom automation interface or to interface with existing automation or control equipment.

The DELAY time (seconds) display

As previously mentioned, the DELAY time display indicates the time duration of the program audio in the 6100's memory at any instant in 0.1 second intervals.

6 Troubleshooting

Solutions to common problems

There is no output signal.

- Check the AC power connections to the 6100.
- Check input and output cables and connections.
- Determine that there really is a signal coming from the source and that it is getting to the 6100.

Distortion in the digital output signal.

- Check the input signal. Is it overdriving the 6100's input? If so, the INPUT display should indicate so.
- Is the incoming signal already distorted? Listen "up stream" from the 6100 (or manually place the unit in BYPASS mode) to determine that you are feeding it a clean signal.

Buzz in the output

- Check input and output connector wiring.
- Check for ground loops between interconnected system equipment.
- Are all system components on the same AC ground?

Noise (hiss)

- Check input signal levels and input level control settings. The input may be too low in level. If so, boost the signal from your console or input source.
- Is the input signal already noisy? Listen "up stream" from the 6100 to determine if you are feeding it a clean signal.

Less common problems

The 6100 doesn't power up or doesn't respond properly.

- Consult a qualified service technician or the Symetrix factory.

The 6100 is not plugged in, but works great anyway.

- Consult your doctor or therapist.

7 Warranty and Service

The AirTools™ Limited Warranty

Symetrix, Inc. expressly warrants that AirTools™ products will be free from defects in material and workmanship for eighteen (18) months from the date the product is shipped from the factory. Symetrix's obligations under this warranty will be limited to repairing or replacing, at Symetrix's option, the part or parts of the product which prove defective in material or workmanship within eighteen (18) months from the date the product is shipped from the factory, provided that the Buyer gives Symetrix prompt notice of any defect or failure and satisfactory proof thereof. Products may be returned by Buyer only after a Return Authorization number (RA) has been obtained from Symetrix. Buyer will prepay all freight charges to return the product to the Symetrix factory. Symetrix reserves the right to inspect any products which may be the subject of any warranty claim before repair or replacement is carried out. Symetrix may, at its option, require proof of the original date of purchase (dated copy of original retail dealer's invoice). Final determination of warranty coverage lies solely with Symetrix. Products repaired under warranty will be returned freight prepaid via United Parcel Service by Symetrix, to any location within the Continental United States. Outside the Continental United States, products will be returned freight collect.

The foregoing warranties are in lieu of all other warranties, whether oral, written, express, implied or statutory. Symetrix, Inc. expressly disclaims any IMPLIED warranties, including fitness for a particular purpose or merchantability. Symetrix's warranty obligation and buyer's remedies hereunder are SOLELY and exclusively as stated herein.

This Symetrix product is designed and manufactured for use in professional and studio audio systems and is not intended for other usage. With respect to products purchased by consumers for personal, family, or household use, **Symetrix expressly disclaims all implied warranties, including but not limited to warranties of merchantability and fitness for a particular purpose.**

This limited warranty, with all terms, conditions and disclaimers set forth herein, shall extend to the original purchaser and anyone who purchases the product within the specified warranty period.

Warranty Registration must be completed and mailed to Symetrix within thirty (30) days of the date of purchase.

Symetrix does not authorize any third party, including any dealer or sales representative, to assume any liability or make any additional warranties or representation regarding this product information on behalf of Symetrix.

This limited warranty gives the buyer certain rights. You may have additional rights provided by applicable law.

NOTE: Some AirTools™ products contain embedded software and may also be accompanied by control software intended to be run on a personal computer. Said software is specifically excluded from this warranty.

Limitation of Liability

The total liability of Symetrix on any claim, whether in contract, tort (including negligence) or otherwise arising out of, connected with, or resulting from the manufacture, sale, delivery, resale, repair, replacement or use of any product will not exceed the price allocatable to the product or any part thereof which gives rise to the claim. In no event will Symetrix be liable for any incidental or consequential damages including but not limited to damage for loss of revenue, cost of capital, claims of customers for service interruptions or failure to supply, and costs and expenses incurred in connection with labor, overhead, transportation, installation or removal of products, substitute facilities or supply houses.

Servicing the 6100

If you have determined that your 6100 requires repair services and you live outside of the United States please contact your local AirTools™ dealer or distributor for instructions on how to obtain service. If you reside in the U.S. then proceed as follows.

Return authorization

At the Symetrix factory, Symetrix will perform in-warranty or out-of-warranty service on any product it has manufactured for a period of three years from date of manufacture.



Before sending anything to Symetrix, please contact our Customer Service Department for a return authorization (RA) number. The telephone number is (425) 778-7728. Additionally, support is available via E-mail through tech@symetrixaudio.com or via the web site <http://www.airtoolsaudio.com>.

In-warranty repairs

To get your 6100 repaired under the terms of the warranty:

1. Call us for an RA number.
2. Pack the unit in its original packaging materials.
3. Include your name, address, daytime telephone number, and a brief statement of the problem.
4. Write the RA number on the outside of the box.
5. Ship the unit to Symetrix, freight prepaid. We do not accept freight collect shipments.

Just do these five things, and repairs made in-warranty will cost you only one way freight charges. We'll pay the return freight.

If you don't have the factory packaging materials, we recommend using an oversize box. Wrap the unit in a plastic bag, surround it with bubble-wrap, and place it in the box surrounded by Styrofoam peanuts. Be sure there is enough clearance in the box to protect the rack ears. We won't return the unit in anything but Symetrix packaging for which we will have to charge you. If the problem is due to operator misuse or error, you will have to pay for both parts and labor. In any event, if there are charges for the repair, you will pay for the return freight. All charges will be COD unless you have made other arrangements (prepaid, Visa or Mastercard).

Out-of-warranty repairs

If the warranty period has passed, you'll be billed for all necessary parts, labor, packaging materials, and freight charges. Please remember, you must call for an RA number before sending the unit to Symetrix.

A

Appendix

Specifications

Architects and engineers specifications

The Broadcast Audio Delay shall be a stereo model whose output is delayed by as much as 20 seconds, thereby allowing the operator to delete or "dump" unwanted audio. The Broadcast Audio Delay shall occupy one rack space (1U).

The inputs shall be active balanced bridging designs terminated with 3-pin XLR (AES/IEC standard wiring) female jacks.

The outputs shall be active balanced designs terminated with 3-pin XLR (AES/IEC standard wiring) male jacks.

Overall frequency response shall be 20Hz to 20kHz, +/- 1dB, measured at +4dBu output. There shall be no more than 0.01% harmonic distortion measured under the following conditions: +4dBu input, +4dBu output, 20 second delay, 1000Hz test frequency.

When the unit is inoperative (either by loss of power, or via the BYPASS switch), the inputs and outputs shall be wired together.

The Broadcast Audio Delay shall be capable of operating by means of its own built-in power supply connected to 100-240 VAC, 50-60 Hz, 25 W.

The Broadcast Audio Delay shall be a Symetrix, Incorporated model 6100 BROADCAST AUDIO DELAY.

Technical specifications

Input/Output Connectors

Inputs	stereo, balanced bridging
Outputs	stereo, electronically balanced
Input Connectors	XLR, BNC (Word Clock, TC89 Time Code)
Output Connectors	XLR, BNC (TC89 Time Code)
Polarity	Pin 2 high
Maximum Input Level	+28 dBu
Maximum Output Level	+28 dBu into 100k ohms
Input Common Mode Rejection	>40 dB @ 1 kHz

Performance Data

Frequency Response	20 Hz to 20 kHz, +/- 1dB at +4dBu output
Harmonic Distortion	less than 0.01% with +4dBu input, +4dBu output, 20 second delay and a 1 kHz test frequency
Typical Dynamic Range	
A/D	-110 dB (A-weighted)
D/A	-115 dB (A-weighted)
A/D and D/A Conversion	24-bit sigma delta
Internal Sampling Rate	48 kHz
External Digital Sync Range	30 to 50 kHz, AES and Word Clock

Physical

Size (HWD)	1.72 in. x 19 in. x 8.2 in. plus connectors 4.37 cm x 48.30 cm x 17.145 cm
Shipping Weight	8 lbs, 3.64 kg

Electrical

Power Requirements	100 VAC to 240 VAC, 50 Hz to 60 Hz, 25 W
--------------------	--

B Appendix

Remote Indicator & Control Interface wiring

Many of the 6100's most important control buttons and LED indicators may be wired to a user supplied panel via the DB-25 multi-pin male connector on the 6100's rear panel. The following tables detail the pin functions. The remote switches and LED indicators are electrically isolated from the switches and LEDs on the 6100's front panel, but effectively operate in parallel (i.e. simultaneously) with them. The Symetrix RC-610 is also available to directly interface to this port and provide all of the functions detailed in this pinout.

Remote panel switch pinouts

<u>Function</u>	<u>Pin #</u>
START	1
EXIT	4
DUMP	7
COUGH	10
BYPASS	14
Switch Common	13

Note: The remote switches used should be high quality, momentary, single pole, push button type. All switches should return to pin #13, the switch common point.

Note: The BYPASS switch can be either a momentary or toggle. If the switch is on for more than a half second, it is treated as a toggle switch and the 6100 will be forced into BYPASS no matter the current bypass state. Shorter activation results in a bypass on/off toggle.

Remote panel LED indicator pinouts

<u>Function</u>	<u>LED Cathode</u>	<u>LED Anode</u>
3.5 Seconds	pin 3	pin 2
7.5 Seconds	pin 6	pin 5
START	pin 9	pin 8
EXIT	pin 12	pin 11
DUMP	pin 16	pin 15
COUGH	pin 18	pin 17
BYPASS	pin 20	pin 19
OPERATE	pin 22	pin 21

Note: Within the 6100, all LED anodes connect to +5V through 220 ohm resistors and all LED cathodes are grounded. No external resistors are required.

Typical remote panel switch wiring

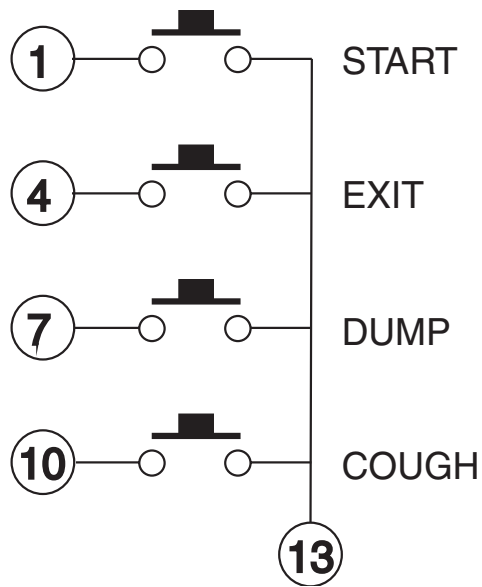

Typical remote panel LED wiring

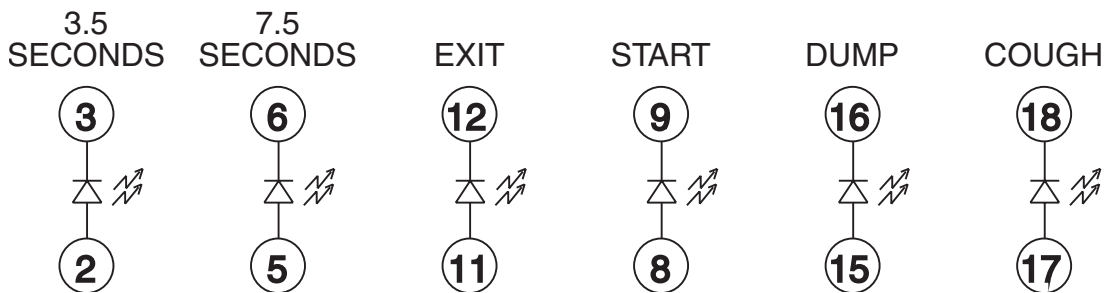

Note: The numbers within the circles refer to pins on the 6100's rear panel DB-25 connector which is labelled REMOTE INDICATOR & CONTROL INTERFACE.

C Appendix

Automation wiring

Automation connector pinout

	<u>Function</u>	<u>Pin #</u>
Relay 1	Common	1
	Normally Closed	2
	Normally Open	3
Relay 2	Common	4
	Normally Closed	5
	Normally Open	6
Relay 3	Common	7
	Normally Closed	8
	Normally Open	9
Relay 4	Common	10
	Normally Closed	11
	Normally Open	12
	LED 1 (A1)	13
	LED 2 (A2)	14
	LED 3 (A3)	15
	LED 4 (A4)	16
LED Return	17	
Automation Button Closures	Auto In 1	18
	Auto In 2	19
	Auto In 3	20
	Auto In 4	21
	Auto In Ground	22

D Appendix

RS-232/RS-485 Control Protocol

Introduction

About the 6100 control protocol

With this protocol, one can control certain functions of the 6100 with any programmable RS-232 or RS-485 controller via the RS-232 or RS-485 port on the rear panel of the 6100. The information that follows will define and illustrate the data string structure used to communicate with the 6100 via RS-232 or RS-485.

Conventions used in the protocol documentation

A dollar sign "\$" preceding a set of two alphanumeric characters denotes a hex value. All other number values should be considered decimal values. Ex., "\$A0" represents the decimal value of "160".

Getting Started

Data string format

The data string consists of an address header, a byte count, the command, optional parameters and a trailing checksum. The address header consists of the address escape byte, <\$FB>, and the number of the addressed unit, <\$ADDR>. The <\$FB> signals the beginning of a data string as well as an escape for the end of one. Anywhere a <\$FB> byte is present in the outgoing data stream, it must be escaped with another <\$FB> byte to indicate that the byte is to be treated as a data value and not the address mark. This additional escape byte is not factored into the checksum. The <\$ADDR> is the unit ID number (\$01-\$FF or 1-255). The MSB and LSB byte count indicate the number of bytes to follow (not including any <\$FB> escape bytes). The MSB and LSB together are treated as a 16 bit unsigned quantity, the MSB being the upper byte and the LSB the lower. The MSB will always be zero unless the command stream is more than 255 bytes long.

Here is another way to look at it:

PART	LENGTH	DESCRIPTION
Address Header	2 bytes	byte 1: Escape byte <\$FB> byte 2: Device Address <\$ADDR> (\$01-\$FF or 1-255)
Data String Size	2 bytes	byte 1: MSB = normally zero (see above paragraph) byte 2: LSB = Command (1 byte) + Parameters (nn bytes) + Checksum (1 byte)
Command & Parameters	1 byte nn bytes	For example, \$91 (Bypass Control) Format and size varies by command type
Checksum	1 byte	See Checksum on page 20

Data string construction

An example command string: Set the 6100 to BYPASS mode using \$91 Bypass Control.

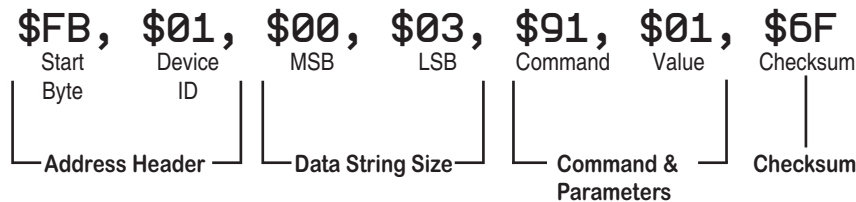

An example return status string: No error.



Returned codes

Returned status codes:

\$00: no error
\$01: invalid data
\$02: invalid command code

Device type codes:

\$61: 6100 Broadcast Audio Delay

Manufacture's code

\$38: Symetrix

Checksum

The checksum is the 2's complement of the LSB byte of the (32 bit internal) checksum. To compute the checksum, ignore the initial **<\$FB>** and **<\$ADDR>** bytes of the string so you are left with the MSB, LSB, command, and parameter data. Add the remaining bytes. Here is a simple formula:

sum = sum AND **\$FF** :make sure the sum is less than **\$100** (256 in decimal)
checksum = **\$100** - sum :take the two's complement of sum

Example:

Data String with out checksum: **\$FB, \$01, \$00, \$03, \$91, \$01** (251, 1, 0, 3, 145, 1 in decimal)
Remove FB and address bytes: **\$00, \$03, \$91, \$01** (0, 3, 145, 1 in decimal)
Add remaining bytes: **\$95** (149 in decimal)
Ignore all but the bottom byte: **\$95** (149 in decimal)
Two's compliment: **\$6B** (107 in decimal)
Data String with checksum: **\$FB, \$01, \$00, \$03, \$91, \$01, \$6B** (251, 1, 0, 3, 145, 1, 107 in decimal)

Commands

Write commands

\$90 Remote Switch Control - Control the EXIT, START, COUGH and DUMP switches remotely

Note: The EXIT, START and DUMP buttons are remotely pressed once when the mask bit is set. The COUGH button will remain active for as long as the mask bit is set.

SEND	RECEIVE	DESCRIPTION
\$FB		address mark
\$ADDR		unit address (1-255)
\$00		(MSB) number of bytes to follow
\$03		(LSB) including command and checksum
\$90		command
\$nn		switch mask (0: EXIT, 1: START, 2: COUGH, 3: DUMP) BIT (state per bit: 0 = switch off, 1 = switch on)
\$nn		checksum (of all received bytes after addressing)
	\$ADDR	unit address (1-255)
	\$DT	device type
	\$ID	manufacturer's code
	\$00	(MSB) number of bytes to follow
	\$02	(LSB) including status and checksum
	\$nn	returned status
	\$nn	checksum (of all returned bytes)

\$91 Bypass Control - Set the 6100's operational status to BYPASS or OPERATE

SEND	RECEIVE	DESCRIPTION
\$FB		address mark
\$ADDR		unit address (1-255)
\$00		(MSB) number of bytes to follow
\$03		(LSB) including command and checksum
\$91		command
\$nn		bypass control (0: NORMAL OPERATION, 1: BYPASSED)
\$nn		checksum (of all received bytes after addressing)
	\$ADDR	unit address (1-255)
	\$DT	device type
	\$ID	manufacturer's code
	\$00	(MSB) number of bytes to follow
	\$02	(LSB) including status and checksum
	\$nn	returned status
	\$nn	checksum (of all returned bytes)

Read commands

\$02 Get Device Type and Unit ID codes - returns the Device Type and Unit ID codes

SEND	RECEIVE	DESCRIPTION
\$FB		address mark
\$ADDR		unit address (1-255)
\$00		(MSB) number of bytes to follow
\$02		(LSB) including command and checksum
\$02		command
\$FC		checksum (of all received bytes after addressing)
	\$ADDR	unit address (1-255)
	\$DT	device type
	\$ID	manufacturer's code
	\$00	(MSB) number of bytes to follow
	\$02	(LSB) including status and checksum
	\$nn	returned status
	\$nn	checksum (of all returned bytes)

\$10 Get Software Statistics - returns software statistics

SEND	RECEIVE	DESCRIPTION
\$FB		address mark
\$ADDR		unit address (1-255)
\$00		(MSB) number of bytes to follow
\$02		(LSB) including command and checksum
\$10		command
\$EE		checksum (of all received bytes after addressing)
	\$ADDR	unit address (1-255)
	\$DT	device type
	\$ID	manufacturer's code
	\$00	(MSB) number of bytes to follow
	\$0C	(LSB) including status and checksum
	\$nn	host revision number *100, (MSB)
	\$nn	host revision number *100, (LSB)
	\$nn	host revision day
	\$nn	host revision month
	\$nn	host revision year (20<nn>)
	\$nn	dsp revision number *100, (MSB)
	\$nn	dsp revision number *100, (LSB)
	\$nn	dsp revision day
	\$nn	dsp revision month
	\$nn	dsp revision year (20<nn>)
	\$nn	returned status
	\$nn	checksum (of all returned bytes)

\$11 Get Realtime Status - returns the Device Type and Unit ID codes

SEND	RECEIVE	DESCRIPTION
\$FB		address mark
\$ADDR		unit address (1-255)
\$00		(MSB) number of bytes to follow
\$02		(LSB) including command and checksum
\$11		command
\$ED		checksum (of all received bytes after addressing)
	\$ADDR	unit address (1-255)
	\$DT	device type
	\$ID	manufacturer's code
	\$00	(MSB) number of bytes to follow
	\$0C	(LSB) including status and checksum
	\$nn	current makeup percentage (0.5% steps, 0-200)
	\$nn	current makeup time (0.1 second steps, 0-200)
		<u>Note:</u> level values are 0.5dB/step below 0dBFS
	\$nn	CH 1 level
	\$nn	CH 2 level
	\$nn	current input source (0: analog, 1: digital)
	\$nn	external sync source status
		BIT 0: word clock status (0: no clock, 1: locked)
		BIT 1: AES/EBU clock status (0: no clock, 1: locked)
	\$nn	Bypass/button led status
		BIT 0 set: unit is bypassed
		BIT 1 set: exit button is illuminated
		BIT 2 set: start button is illuminated
		BIT 3 set: cough button is illuminated
		BIT 4 set: dump button is illuminated
	\$nn	(MSB) sample rate in Hz
	\$nn	(MID)
	\$nn	(LSB) sample rate
	\$nn	returned status
	\$nn	checksum (of all returned bytes)

E Appendix Block Diagram

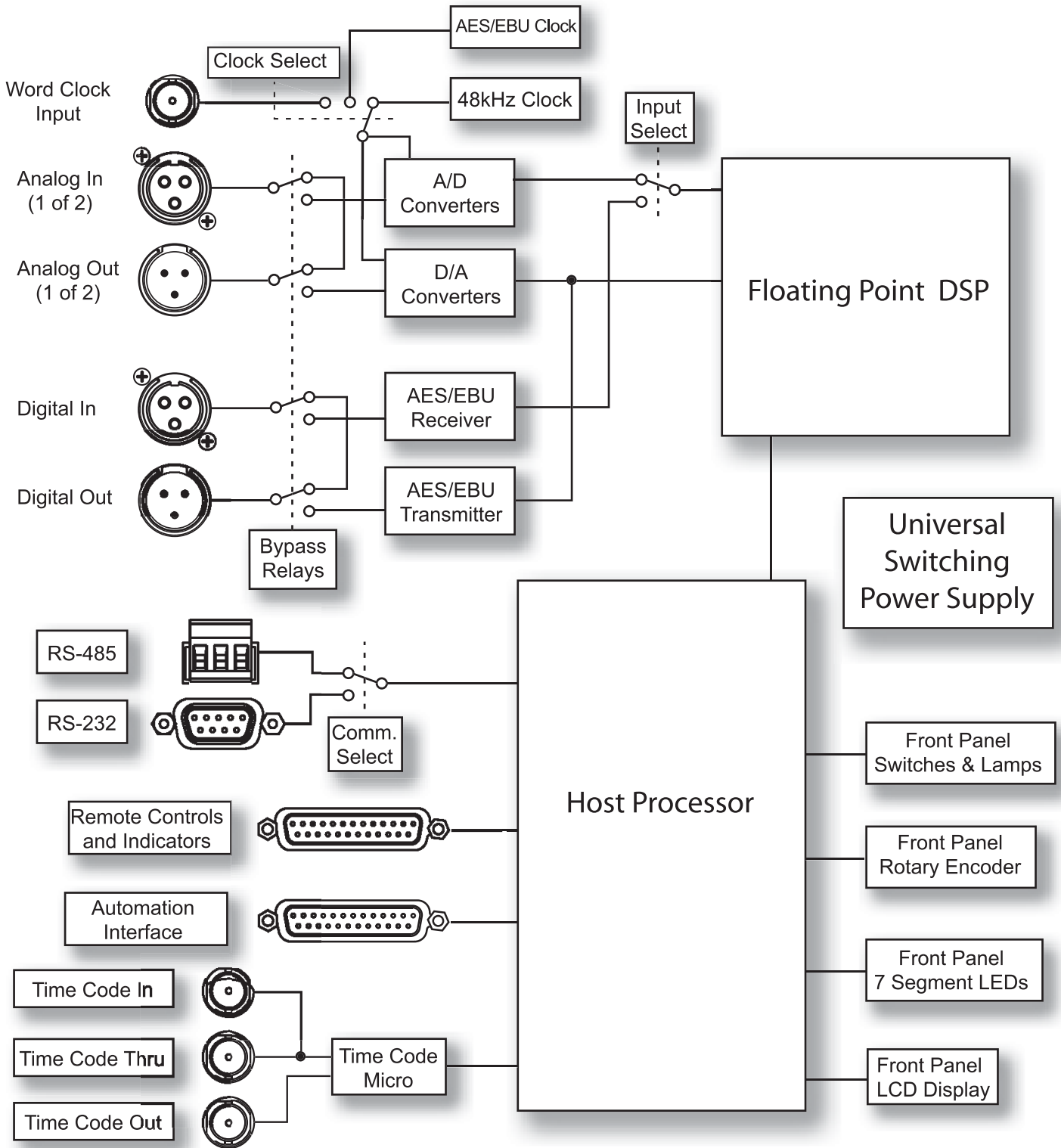

airTools™

Engineered by  Symetrix

6408 216th St. SW, Mountlake Terrace, WA, USA • Tel (425) 778-7728 • Fax (425) 778-7727 • Web www.airtoolsaudio.com

Copyright 2002, Symetrix, Inc. All rights reserved.

AirTools™ is a registered trademark of Symetrix, Inc.

All other trademarks referenced in this User's Guide are the property of their respective holders.

Under copyright laws, the content of this User's Guide remains the property of Symetrix, Inc.