

LCD DISPLAY
WIRELESS RECEIVER MODULE

ACT-707 MB/MC

Instruction Manual

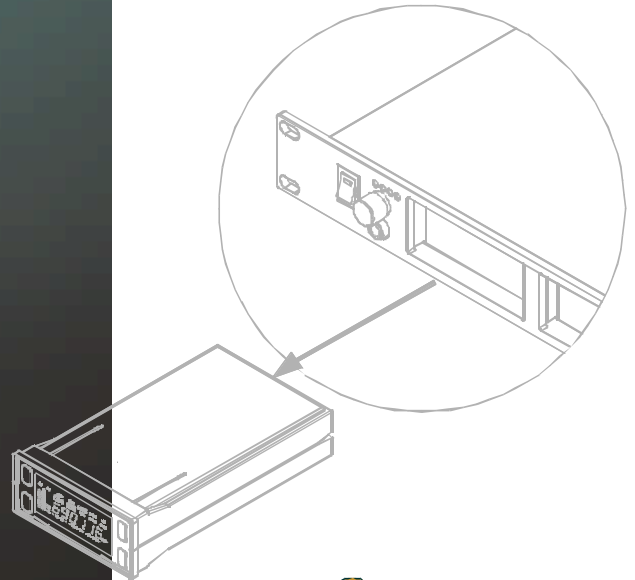

MIPRO Electronics Co., Ltd.

Head office: 814, Pei-Kang Road, Chiayi, 600, Taiwan.

Taipei office: 5, Lane 118, Sung-teh Road, Taipei, 110, Taiwan.

Web-http: //www.mipro.com.tw E-mail: mipro@mipro.com.tw



FCC
CE06810
CE01970

MIPRO

LCD DISPLAY WIRELESSRECEIVER MODULE

Thankyou for choosing MIPRO'sACT-707 MB/MC (LCD Display Wireless Receiver Module). To bring the maximum performance out of the system and know the system better, please take user's time and read this instruction thoroughly.

The display panel is a modularized mono-colored LCD display thatcan display various information of operation and perform ACT feature.

This system includes the following accessories:
Instruction Manual x 1

1. Full Display ofLCD Screenand Locations of buttons

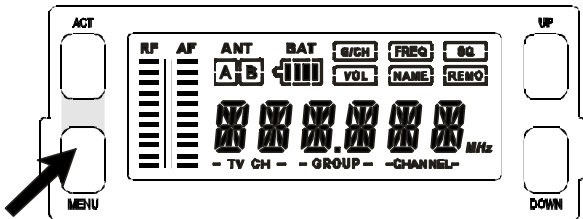

LCD DISPLAY WIRELESSRECEIVER MODULE

2. Designations of buttons and Functions

MENU: Enable user to select from one functiontotheother

"MENU" button allows user to select a mong 6 options (in the sequence showing below) thateach is surroundedin a square frame and shown on the upper half of LCD display. Detail functionsandoperationsare as follows.

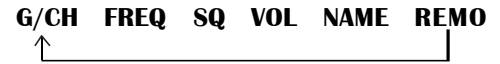

(1) G/CH: Indicatesorsetupsthe receiver GROUP and CHANNEL.

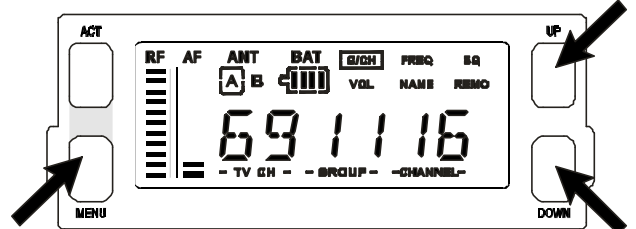

A. Operating Procedures.

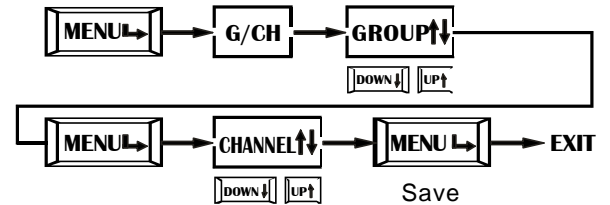

B. How to Operate?

- In the lowerrow ofLCDdisplay, T V CHANNEL, GROUP, and C HANNELare separatelyshown in dual-digit numbers(fromlefttoright).
- Push"UP" or " DOWN" button once and the number above "GROUP" will start b linking. Push "UP" or "DOWN" button now will permituserto change to another pre-programmed group. Push "MENU" button to confirm the modification andgroupnumber will stop blinking.

LCD DISPLAY WIRELESSRECEIVER MODULE

- c. Repeat the same process as above for "CHANNEL" and verify the modification by pushing "MENU" button and channel number will stop blinking.

(2) **FREQ:** Indicates the frequency that is currently in use.

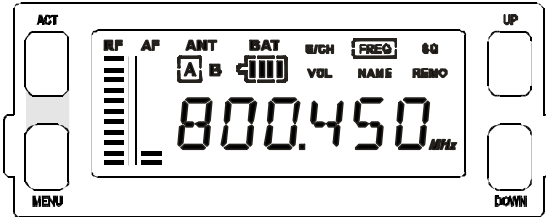

A. Operating Procedures.



B. How to Operate?

- a. After push "MENU" button and select the "FREQ" frame, it will show the frequency that is set under the GROUP and CHANNEL that one had selected previously.
- b. This function cannot be used for frequency alternation.

(3) **SQ:** Indicates or setups the Squelch level.

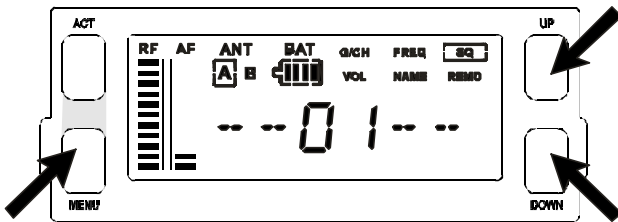

LCD DISPLAY WIRELESSRECEIVER MODULE

A. Operating Procedures.

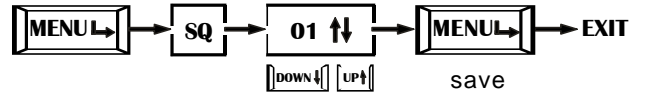

B. How to Operate?

- a. User can set the squelch level within the range of 01-99.
- b. To set the squelch level, simply by pushing the "UP" or "DOWN" button and confirm the modification by pushing "MENU" button.

(4) **VOL:** Indicates Volume Level is at On or Mute position.

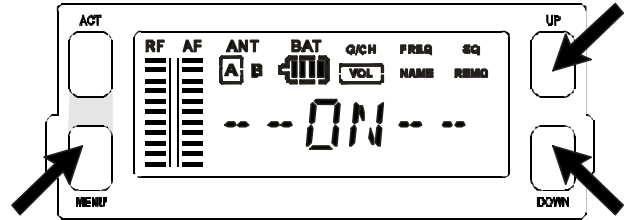

Switching From Audible To Mute

A. Operating Procedures.

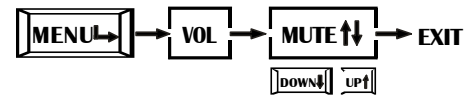

B. How to Operate?

Push "UP" or "DOWN" Button allows one to switch volume to "ON" or "Mute" status.

LCD DISPLAY WIRELESSRECEIVER MODULE

C. CAUTIONS :

AF bar and Ant. A, B of LCD panel will not displayed when the receiver module is at Mute status. To ascertain if receiver is at Mute status, press Menu key, select Volume. If LCD indicates "Mute" it is a Mute status. If LCD indicates "On" audio is operating normally.

(5) NAME: Indicates or setup the name of current channel user.

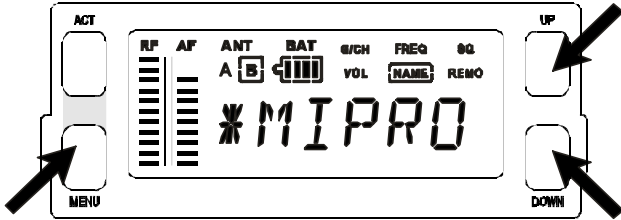

A. Operating Procedures.

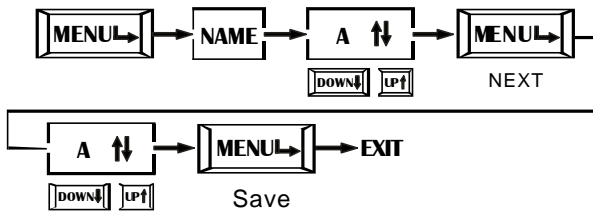

B. How to Operate?

- Maximum 6 characters are allowed (Select from capitalized English letter, numbers, + - x / , and space).
- Push "UP" or "DOWN" button into setup mode and the character on the far left will start blinking. (There will be no blinking if there is no character in the specific space).
- Push "UP" or "DOWN" button to select desired character and confirm by pushing the "MENU" button. Once confirmed, the next character will start blinking and ready for setup.
- Repeat step c until ALL 6 characters are set.

LCD DISPLAY WIRELESSRECEIVER MODULE

(6) REMO: Indicates or setup the receiver address and status of remote controlling.

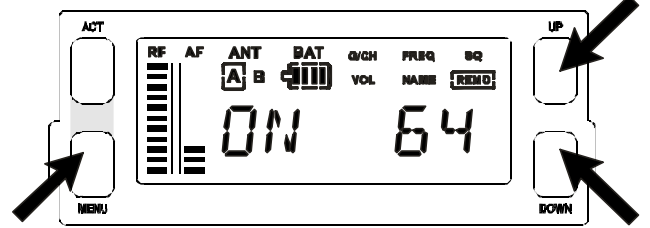

A. Operating Procedures.

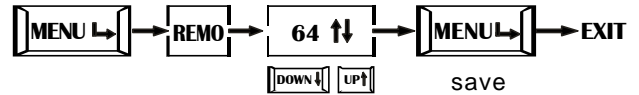

B. How to Operate?

- ACT-BUS interface is adapted for MIPRO Wireless Receiver Module. With MIPRO Interface Converter and Monitoring Software, up to 64 receiver modules can be remote-controlled simultaneously via a P.C.
- Address can be set within the range of 01-64. Under remote control mode, each receiver module MUST have its own address. If 2 different receiver modules are using the same address, it will cause conflict and result in monitoring error. However, if not under remote control mode, operation will remain normal even if 2 different receiver modules are using the same address.
- In remote control mode, "ON" will be shown in the LCD display panel and the number next to the message is the address of the receiver module. However, "OFF" will be shown if the system is not remotely linked to the PC.
- Push "UP" or "DOWN" button to change receiver address and verify by pushing the "MENU" button.

HANDHELD WIRELESS MICROPHONE

3. FUNCTIONS OF LCD DISPLAY

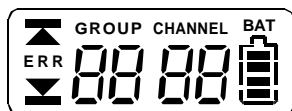

1. **ERR Message:** When "ERR" appears, it means "Error with the system". Please refer to the following codes to diagnose which error you are experiencing.

ERR no01	EEPROM is not being programmed or internal data error.
ERR no02	Testing only.
ERR no03	The frequency you are about to program into the system exceeds microphone's upper limit. (At this time, microphone is still operatable and the frequency remains unchanged. To clear to "ERR" message in LCD display, simply turns off the power and switch back on.)
ERR no04	The frequency you are about to program into the system is below microphone's frequency lower limit. (At this time, microphone is still operatable and the frequency remains unchanged. To clear to "ERR" message in LCD display, simply turns off the power and switch back on.)
2. **"Group" & "Channel " :** When both items are shown, they indicate that the user is currently using the pre-programmed frequency in the receiver.
3. **"Channel" Only :** If "Channel" is the only item shown in the display, it indicates the user is using the personalized frequency. (Such frequency can only be programmed via MIPRO's ACT Software and available for ACT-707B and ACT-707C only.)

HANDHELD WIRELESS MICROPHONE

4. Battery Status:

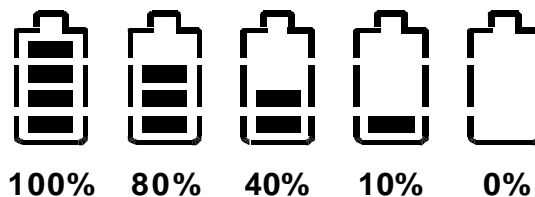

Battery Status: When the battery has less than 10% power remaining, LED indicator will lit to remind you to replace the battery. If undervoltage, LCD will show "PoFF" and shut down the system to avoid battery being over-discharged.

5. Switch Off:

When switch the power knob to "Off" position, LCD will show "PoFF" first. Then, the system is completely shut down and no further message will be displayed.

BELT PACK TRANSMITTER

3. Battery Status Indicator: Indicates the power on / off and battery status.
 - (a) When power switch is turned on: The LED indicator flashes briefly, indicating normal battery status.
 - (b) When RED light illuminates at either power on or during usage: The battery level is low, therefore, a new battery replacement is thus necessary.
4. Transmitting Antenna: 1/ 4 transmitting antenna.
5. Transmitter Housing: Packages the PCB and battery.
6. Functions of LCD Display
7. Act Signal Receptor
8. Gain Control: Adjusts the desirous input gain.
9. GT/MT Level Select Switch: Switch GT position for electric guitar usage and "Line In". Gain Control is irrelevant for "GT". Switch to "MT" for condenser microphone or wired microphone. Gain Control works in "MT" for input sensitivity adjusting.
10. Battery Compartment and Cover: Accommodates two 1.5V(AA) batteries.
11. Detachable Belt Clip: Allows 360 degrees rotating to suit transmitting angles. To detach simply use a screwdriver at a 45 degree angle to unfasten. see diagram.

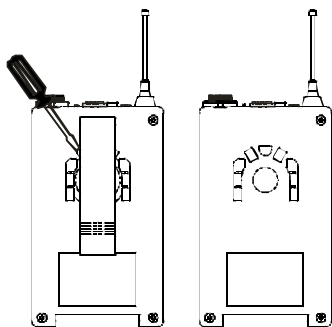

- 15 -

BELT PACK TRANSMITTER

2. OPERATING INSTRUCTIONS

1. To adjust GT/MT Switch (10), and Gain Control (8), simply push down both snap locks on the sides of battery cover and flip it backwards to expose the adjustment panel.
2. Before power on, ascertain if same channel (7) was set up for both receiver and microphone. If not adjust to same channel accordingly.
3. The LED indicator flashes briefly when power on indicating normal battery status. If no flash occurs it has either no battery, the battery is drained or installed incorrectly. Change accordingly.
4. Plug the microphone connector into the input jack (1) and tighten the connector screw by clockwise direction as shown in (Fig. 2).

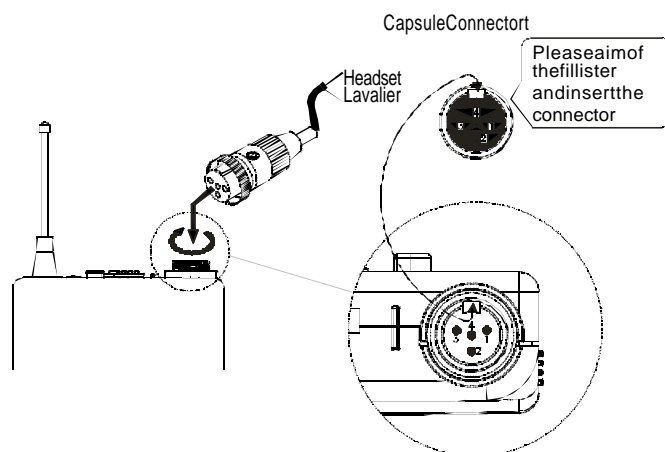

(Fig.2)

- 16 -

BELT PACK TRANSMITTER

3. AF INPUT CONNECTIONS

(1) 2-Wire Electret condenser microphone Capsule

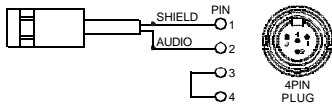

(2) 3-Wire Electret condenser microphone Capsule

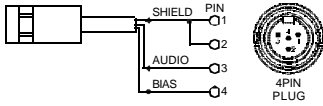

(3) Dynamic Microphone

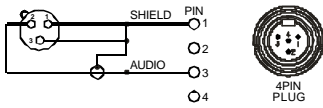

(4) Electric Guitar

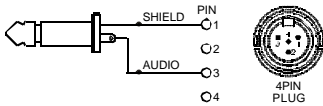

(5) Line-in (Impedance 8K ATT. 10dB)

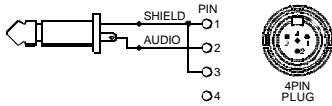

BELT PACK TRANSMITTER

4. FUNCTIONS OF LCDDISPLAY

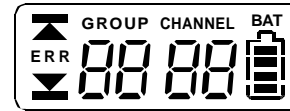

- 1. ERR Message:** When "ERR" appears, it means "Error with the system" Please refer to the following codes to diagnose which error you are experiencing.

 - ERR no01 EEPROM is not being programmed or internal data error.
 - ERR no02 Testing only.
 - ERR no03 The frequency you are about to program into the system exceeds microphone's upper limit. (At this time, microphone is still operatable and the frequency remains unchanged. To clear to "ERR" message in LCD display, simply turns off the power and switch back on.)
 - ERR no04 The frequency you are about to program into the system is below microphone's frequency lower limit. (At this time, microphone is still operatable and the frequency remains unchanged. To clear to "ERR" message in LCD display, simply turns off the power and switch back on.)
- 2. "Group" & "Channel " :** When both items are shown, they indicate that the user is currently using the pre-programmed frequency in the receiver.
- 3. "Channel" Only :** If "Channel" is the only item shown in the display, it indicates the user is using the personalized frequency. (Such frequency can only be programmed via MIPRO's ACT Software and available for ACT-707B and ACT-707C only.)

BELT PACK TRANSMITTER

4. Battery Status:

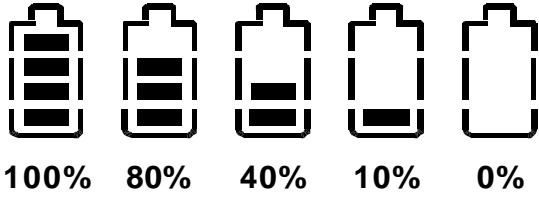

Battery Status: When the battery has less than 10% power remaining, LED indicator will lit to remind you to replace the battery. If undervoltage, LCD will show "PoFF" and shut down the system to avoid battery being over-discharged.

5. Switch Off:

When switch the power knob to "Off" position, LCD will show "PoFF" first. Then, the system is completely shut down and no further message will be displayed.

BELT PACK TRANSMITTER

5. BATTERY INSTALLATION

1. Pushing down both snap locks on the sides of battery cover to open battery cover. Take out the batteries. Fig.(2).
2. Insert a two 1.5(AA) batteries into the battery compartment according to the correct polarity as shown in Fig. (3). Then push up to close the battery compartment as shown in Fig. (3).

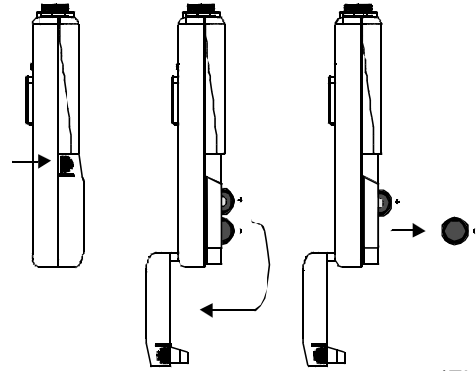

(Fig.2)

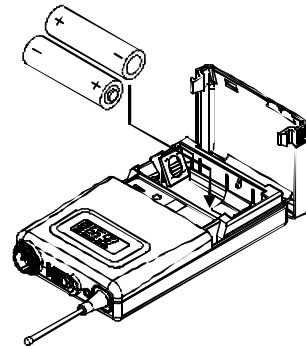

(Fig.3)

