

# MIPRO Electronics Co., Ltd.

Head office: 814, Pei-Kang Road, Chiayi, 600, Taiwan.

Taipei office: 5, Lane 118, Sung-teh Road, 100, Taipei, Taiwan.

Web-http: [//www.mipro.com.tw](http://www.mipro.com.tw)

E-mail: [mipro@mipro.com.tw](mailto:mipro@mipro.com.tw)

FC  
CE0681①  
CE0197①



2CE143 ®

# MIPRO

## ACT-707DE Dual Channel Wireless Receiver

### Instruction Manual



## DUAL CHANNEL RECEIVER

1. INTRODUCTION -----	1
2. PARTS NAMES AND FUNCTIONS -----	2-3
3. INSTALLATION OF THE RECEIVER-----	4-5
4. RECEIVER OPERATING PROCEDURES-----	6
5. SWITCHABLE CHANNELS FUNCTIONS -----	7
6. ACT BUTTON-----	7
7. CAUTIONS -----	8

## HANDHELD WIRELESS MICROPHONE

1. PARTS NAMES AND FUNCTIONS -----	10
2. BATTERY INSERTION -----	11
3. OPERATING INSTRUCTIONS -----	11
4. CAUTIONS -----	11

## BELT PACK TRANSMITTER

1. PARTS NAMES AND FUNCTIONS -----	12-13
2. OPERATING INSTRUCTIONS -----	13
3. AF 4-PIN INPUT CONNECTION METHODS -----	14
4. BATTERY INSERTION -----	15
5. CAUTIONS-----	15

## 1. INTRODUCTION

Thanks for choosing the most advanced multi channel wireless receiver system from MIPRO.

Please read this manual thoroughly for correct operating and optimal performance.

In today's audio professionals, the demand for using lots of multi-channel wireless microphone systems simultaneously is greatly increasing. Furthermore, they would like to see professional systems have the capability of easy frequency agility, more non-interfering channels and interference-free operation.

ACT-707DE, houses in an international standard 1-rack case, has LED panel that clearly displays channels, RF and AF meters. It has an "AutoScan" button to auto search for non-interference channels with a simple touch of a button. Concurrently, a simple 1-touch on the "ACT" button will therefore provides rapid and precise channel setting of the transmitter, avoiding possible errors or mechanical breakdowns. This system is perfect for single system usage under all professional applications. Space saving, stable performance, easy to operate and couple with unbeatable prices make it an attractive package.

### Included Accessories :

Antennas × 2  
Instruction Manual × 1

Audio Output Cable × 1  
Rack-mount Brackets × 1-pair

## DUAL CHANNEL RECEIVER

### 2. PARTS NAMES AND FUNCTIONS

#### Front Panel :

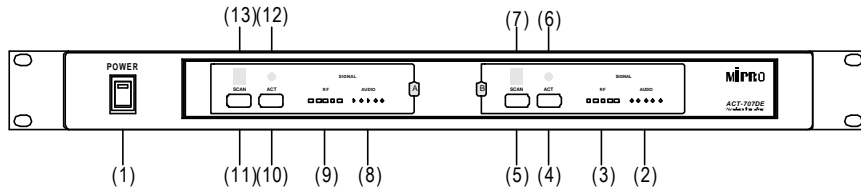

(Fig.1)

- (1) Power Switch & Indicator: When switch is turned on, red indicator illuminates to denote normal power status.
- (2)(8) Audio Signal Level Indicator: Indicate the audio signal level.
- (3)(9) RF Signal Level Indicator: Indicate the RF signal strength received.
- (4)(10) ACT Button: To setup microphone frequency to match receiver frequency.
- (5)(11) Scan Button: Press once to select receiving channel and autoscan the whole bandwidth to avoid interference channel.
- (6)(12) ACT Indicator : Indicate if ACT function is activated.
- (7)(13) Channel Indicator: To display system's receiving channel.

## DUAL CHANNEL RECEIVER

#### Rear Panel :

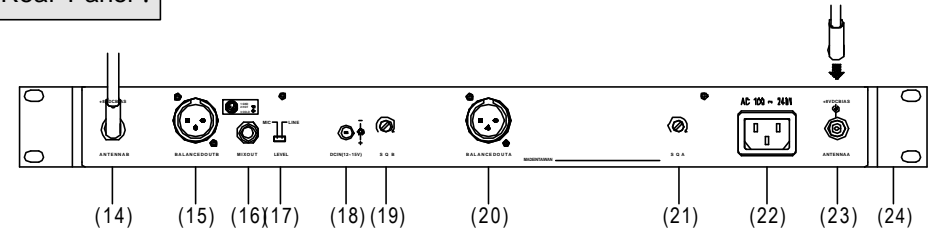

(Fig.2)

- (14) Rear Antenna B input Connector: B Antenna connector can be installed with antenna directly and provides power for antenna booster..
- (15)(20) Balanced Audio Output Jack: With Cannon / XLR type connector provides balanced audio output signal from this jack to the amplifier.
- (16) Unbalanced Audio Mixed Output Jack : With 1/ 4 Phone Jack provides the mixed unbalanced audio output signal from this jack to the amplifier. Switch between "LINE" and "MIC" for different purposes.
- (17) Unbalanced Level Switch: "MIC" selection is for "Microphone-level" output. "LINE" selection is for "Line-out" level output.
- (18) DC 12V Input Jack: To connect 12 VDC from the AC/DC adapter.
- (19)(21) Squelch Adjuster: Adjust the squelch level to eliminate the RF noise interference at receiver stand-by state.
- (22) AC Input Jack: To connect 85 ~ 265 Volts AC power.
- (23) Rear Antenna A input Connector: A Antenna connector can be installed with antenna directly and provides power for antenna booster.
- (24) Rackmount Bracket: To install the receiver into an EIA 19-inch standard rack case.

## DUAL CHANNEL RECEIVER

### 3. INSTALLATION OF THE RECEIVER

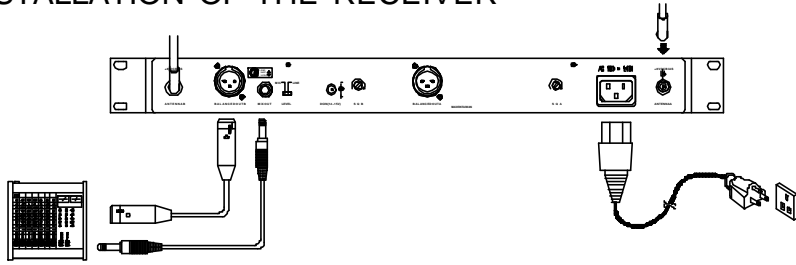

(Fig.3)

1. Install 2 separate antennas on the antenna sockets (14), (23) on the rear panel. Illustrated in figure 3.
2. Power Output Connection:
  - (a) Connect the AC/DC adapter cable to DC 12V INPUT JACK (18), then plug the adapter unit into an appropriate AC outlet with caution to the correct voltage under both AC outlet and adapter marked, as shown in fig. 4.
  - (b) With the appropriate AC power cable connects from AC Input Jack (22) to an AC outlet under the marked voltage 85~265 V, as shown in Fig. 5.

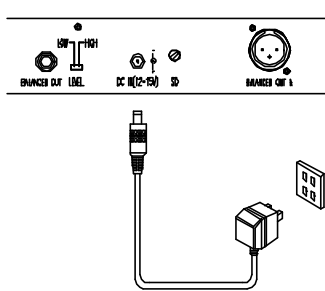

(Fig.4)

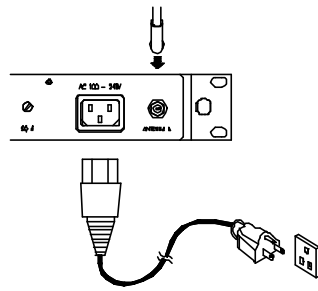

(Fig.5)

### 3. Audio Output Connection:

- (a) Unbalanced Level Switch (17) Setting Position: When inputs the unbalanced output of a receiver into "AUX-IN" input jack of a mixer or amplifier or "Electric Guitar", switch the Level Switch (17) to the right "LINE" position. MIC sensitivity may occur if switch to the wrong position. When input the unbalanced output of a receiver into the "MIC-IN" input jack of a mixer or amplifier; switch the Level Switch (17) to the left "MIC" position. Overload distortion may occur if switching to the wrong position. When using electric guitar, don't use "MIC" position as it may have generated insufficient level.

## DUAL CHANNEL RECEIVER

- (b) Unbalanced Output: Using audio output cable attached with "PHONE PLUG" type, connect one end from the unbalanced output jack (16) of the receiver, and the other end to the "LINE-IN" input jack of the amplifier, as shown in Fig. 3.
- (c) Balanced Output: Using audio output cables attached with "XLR" or "Canon" type, connect one end from the balanced output jacks (15)(20) of the receiver, and the other end to the "MIC IN" input jack of the mixer or amplifier, as shown in Fig. 3. (The characteristic of the 3-pin connector is as shown in Fig. 6
- (d) Guitar Output: Using audio output cable attached with "PHONE PLUG" type, plug one end from the unbalanced output jack of a receiver, and the other end to the input jack of a guitar amplifier. Switch the Level Switch (17) to "LINE" position.

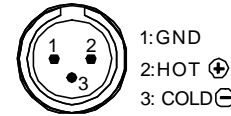

(Fig.6)

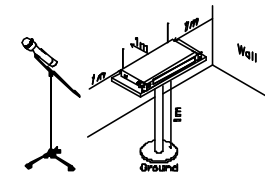

(Fig.7)

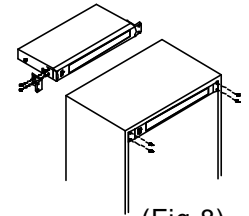

(Fig.8)

4. To ensure best reception possible, receiver must be installed at least one meter above ground. In addition, the distance between transmitter and receiver must be more than one meter and away from noise. (Shows in figure 7)
5. On the front panel of the receiver, 4 openings are pre-drilled for instant installation on the standard 19-inch rack case. (Shows in figure 8)

## DUAL CHANNEL RECEIVER

### 4. RECEIVER OPERATING PROCEDURES

1. Set the volume of the mixer to its minimum before turning on the receiver or transmitters.

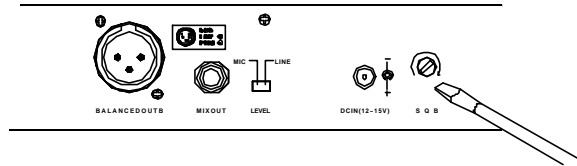

(Fig.9)

2. If SIGNAL LED indicators (3)(9) of the receiver light on before switching on the microphone or transmitter, it indicates the receiver is under interference of noises. The more LEDs light on the more severity of interference. This system has Pititone and NoiseLock dual-squelch features and no sudden noise burst out will occur. If multiple channels are used and both SIGNAL and AUDIO LEDs glow and interference noises appear, simply adjust the Squelch controls (19)(21) clockwise until AUDIO signal indicators to extinguish. (Fig. 9). However, by adjusting the squelch controls, it affects the sensitivity level of the receiver, therefore, shorten the operating distance and decreases the stability.
3. Under normal circumstances, the SIGNAL indicator lights up when a microphone or transmitter is turned on near the receiver to indicate the receiver is ready for normal operation. Once speak into the microphone and the AUDIO LED indicators (2)(8) will glow according to the strength of sound level. If no LED glows or no sound outputs, the system is not function properly, thus it must be checked.
4. The microphone output level needs to be adjusted at the amplifier or mixer. No need to adjust at the receiver itself.

## DUAL CHANNEL RECEIVER

### 5. SWITCHABLE CHANNELS FUNCTIONS

1. Functions:
  - (a) This system incorporates advanced PLL synthesized oscillator design. Preprogrammed with 16 switchable frequencies. Allow the user to freely select any of the preprogrammed frequencies.
2. Change channel when:
  - (a) Existing channel is being interfered or channel is malfunction.
  - (b) Select channel for multiple non-interference usage.
3. Caution while changing channels:
  - (a) When multiple channels are utilized do not change channel to avoid exiting channel interference.
  - (b) Press and hold "Channel" button (5)(11) for more than one second to select desired channel disregard if the channel is under interference.
  - (c) When numeric knob reaches "\_" it indicates an empty channel. Proceed until a numeric number appears.

### 6. ACT BUTTON

1. Press "ACT" button (4)(10) on the front panel of receiver once and the system is ready for "ACT" function.
2. Position the "ACT" marking of the transmitter about 20cm (12-inch) towards the "ACT" button (4)(10) on the receiver as illustrated in below figure.
3. ACT function will be deactivated automatically once the transmitter frequency is locked on.

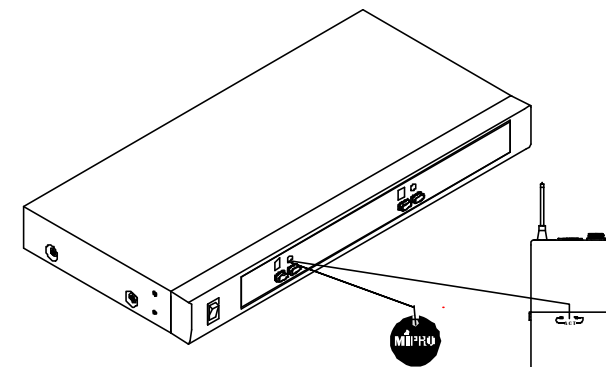



## HANDHELD WIRELESS MICROPHONE

### 1. PARTS NAMES AND FUNCTIONS

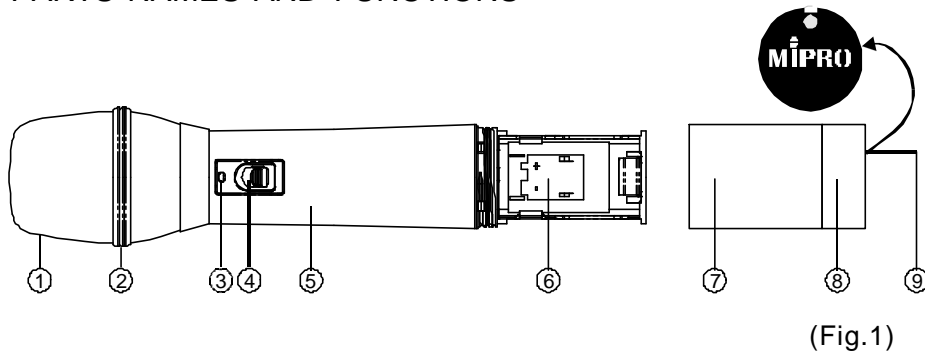

1. Grille: Protects cartridge, prevents "POP" noise and prevents microphone from rolling with polygonal shape.
2. Color Ring: For frequency differentiation.
3. Battery Status Indicator: Indicates power on / off and the battery status. When the power switch is turned ON, the red LEDs indicator flashes briefly, indicating normal battery status. If no flash occurs, it has either no battery or the battery is discharged or installed incorrectly. If after power on the indicator stays lighted, it warns that the battery is weak and should be replaced.
4. Power On-off Switch: Slide the switch for power " ON " or " OFF ".
5. Housing: Upper portion to be connected to capsule module and battery. Internally, it holds transmitter PCB.
6. Battery Compartment: Designed to accommodate one 9 Volt battery.
7. Battery Cap: Covers battery in the battery compartment.
8. Anti-roll Ring: For frequency differentiation.
9. Act Signal Receptor

## HANDHELD WIRELESS MICROPHONE

### 2. BATTERY INSERTION

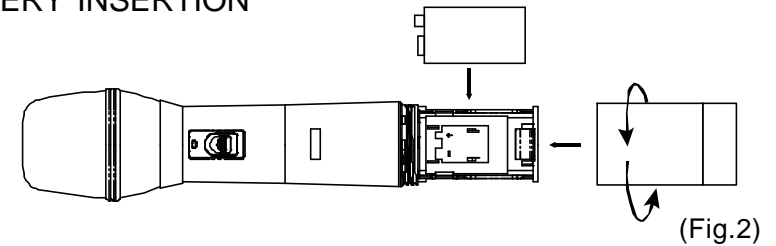

1. Unscrew battery cap in a counter-clockwise direction (7).
2. Insert a 9V battery into the battery compartment according to the correct polarity as shown in Fig.2. The moment the battery touches the terminals, the indicator will flash briefly (7). This means the polarity is correct. However, if no flash occurs, this indicates wrong insertion or that the battery is dead. Please re-insert the battery according to its correct polarity or exchange it for a fresh battery.

### 3. OPERATING INSTRUCTIONS

1. When microphone is switched on:  
When the power is switched on, the indicator will flash briefly indicating normal operation.
2. During Usage:  
The AF LED indicator on the receiver will illuminate according to the audio signal strength from the microphone.
3. When the microphone is not in use:  
Make sure that you turn off the microphone after use to extend the battery life. Remove the battery from the battery compartment if microphone is not to be used again for some time. If a rechargeable battery was used, take it out and recharge it.

### 4. CAUTIONS

Under normal operation, when receiver and transmitter are paired together to set frequency, microphone indicator (3) will remain off after ACT setup the frequency. However, if indicator (3) is flashing, it means receiver and transmitter are not in the same frequency band. Please check the stickers on transmitter and receiver to observe if they are sharing the same frequency bands.

## BELT PACK TRANSMITTER

### 1. PARTS NAMES AND FUNCTIONS

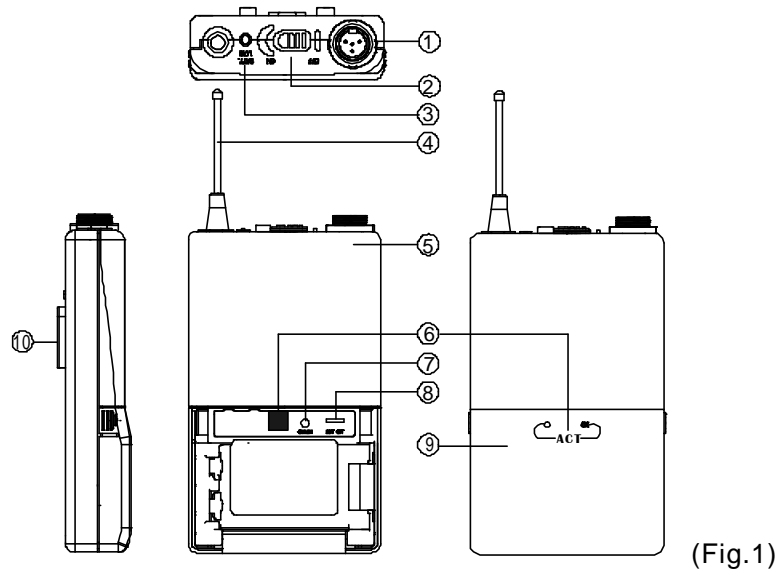

1. AF Input Jack: Connects to either lavalier or headset microphone. (See 5 ways of connection on AF Input Connections)
2. Power Switch: Switch to ON position for operation. Switch to OFF position when not in use.
3. Battery Status Indicator: Indicates the power on / off and battery status.
  - (a) When power switch is turned on: The LED indicator flashes briefly, indicating normal battery status.
  - (b) When RED light illuminates at either power on or during usage: The battery level is low, therefore, a new battery replacement is thus necessary.
4. Transmitting Antenna: 1/ 4 transmitting antenna.
5. Transmitter Housing: Packages the PCB and battery.
6. Act Signal Receptor
7. Gain Control: Adjusts the desirous input gain.
8. GT/MT Level Select Switch: Switch GT position for electric guitar usage and "Line In". Gain Control is irrelevant for "GT". Switch to "MT" for condenser microphone or wired microphone. Gain Control works in "MT" for input sensitivity adjusting.

12

## BELT PACK TRANSMITTER

9. Battery Compartment and Cover: Accommodates one 9 Volt battery.
10. Detachable Belt Clip: Allows 360 degrees rotating to suit transmitting angles. To detach simply use a screwdriver at a 45 degree angle to unfasten. see diagram.

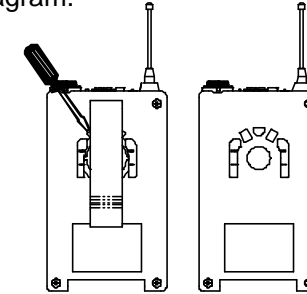

### 2. OPERATING INSTRUCTIONS

1. To adjust GT/MT Switch (8), and Gain Control (7), simply push down both snap locks on the sides of battery cover and flip it backwards to expose the adjustment panel.
2. Before power on, ascertain if same channel was set up for both receiver and microphone. If not adjust to same channel accordingly.
3. The LED indicator flashes briefly when power on indicating normal battery status. If no flash occurs it has either no battery, the battery is drained or installed incorrectly. Change accordingly.
4. Plug the microphone connector into the input jack (1) and tighten the connector screw by clockwise direction as shown in (Fig. 2).

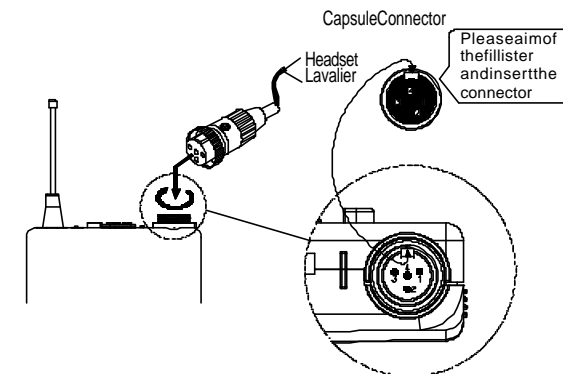

(Fig.2)

13

## BELT PACK TRANSMITTER

### 3. AF 4-PIN INPUT CONNECTION METHODS

#### (1) 2-Wire Electret condenser microphone Capsule

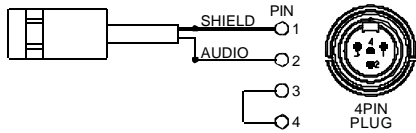

#### (2) 3-Wire Electret condenser microphone Capsule

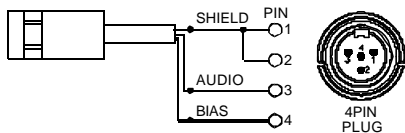

#### (3) Dynamic Microphone

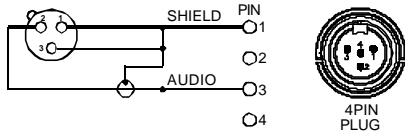

#### (4) Electric Guitar

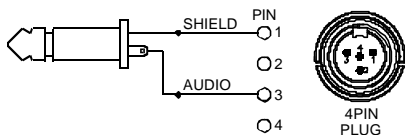

#### (5) Line-in (Impedance 8K ATT. 10dB)

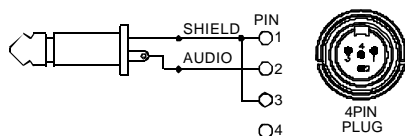

## BELT PACK TRANSMITTER

### 4. BATTERY INSTALLATION

1. Pushing down both snap locks on the sides of battery cover to open battery cover. Take out the batteries. Fig.(3).
2. Insert a 9V battery into the battery compartment according to the correct polarity as shown in Fig. (4). Then push up to close the battery compartment as shown in Fig. (4).

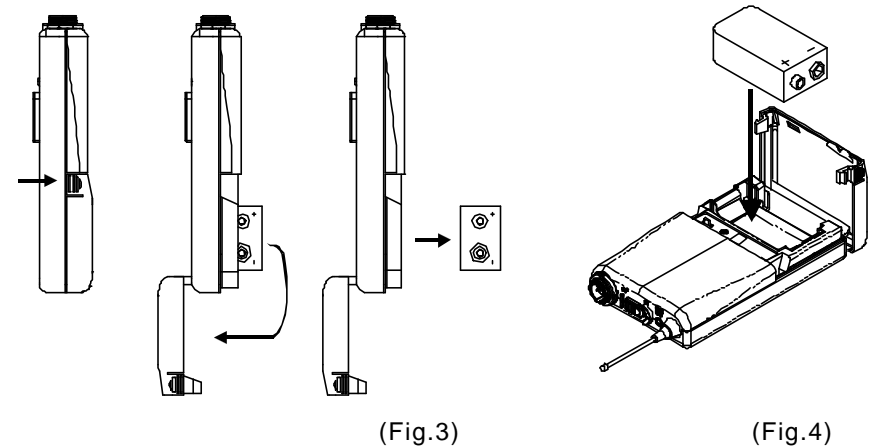

(Fig.3)

(Fig.4)

### 5. CAUTIONS

Under normal operation, when receiver and transmitter are paired together to set frequency, microphone indicator (3) will remain off after ACT setup the frequency. However, if indicator (3) is flashing, it means receiver and transmitter are not in the same frequency band. Please check the stickers on transmitter and receiver to observe if they are sharing the same frequency bands.